

CE

SUMAKE®

PNEUMATIC
TOOLS

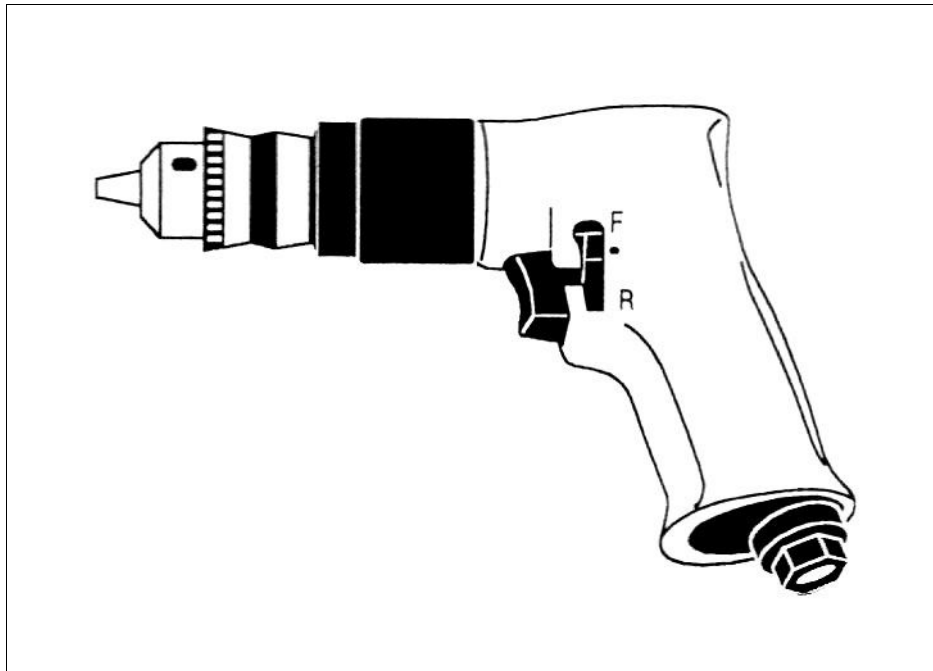

3/8" Air Reversible Drill ST-4431

SPECYFICATION

Free Speed (rpm)	1800
Air Consumption(l/min)	170
Chuck Capacity(mm)	10
Air Inlet Size (inch)	1/4
Overall Length(mm)	180
Air Pressure(kg/cm ³)	6.5(90 PSI)
Weight (kg)	0,9

Test result according to prEN 792-3

Vibration EN 28662-1	Noise ISO 3746:1995(E)	Remark
Load: 0.2 m/s ²	Sound pressure level 92 dB	Should wear an approved ear - protector and gloves while operating tool.
	Sound power level 102,5 dB	
	Instantaneous sound pressure 108 dB	

EC DECLARATION OF CONFORMITY FOR MACHINERY

Manufacturer: SUMAKE INDUSTRIAL CO.,LTD.

Address: 4F,-NO. 351, YANGGUANG ST., NEIHU DISTRICT
TAIPEI CITY 114, TAIWAN

**herewith declares
that:**

ST-4431
3/8" Air Reversible Drill

- is in conformity with the provisions of the Machinery Directive (Directive 89/392/EEC), as amended, and with national implementing legislation:

-and have been tested according to prEN 792....(relevant part)

Taipei, Taiwan MAR / 11 / 1997



.....
Signature

MIKE SU

.....
Full name

Foreword

Sumake is a manufacturer and exporter of air tools since established. We have devote all our effort in improving quality and tools life. As well as the noise and vibration of tools. Bring all of your working efficiency, profits and enjoy using the tool is our principle.

Features

This tool is designed to meet an extremely wide range of materials which need hole drilling by means of proper drill bit.

Operator's instruction

■ Main Applications

This tool is perfect for drilling hole on iron, steel, cast iron, aluminium, nonferrous metal, wood, synthetic resin etc.

■ Cautions for Use

● Air pressure

Maximum performance is displayed at the proper sanding speed, obtainable at a gauge pressure of 6.2 bar. Range-wise, this is an air pressure from 5 to 7 bar (70 to 100 psi)



● Air line

Use a 3/8" air hose between the compressor and the tool. Compressed air is cooled and its water content separated, as soon as the air leaves the compressor. A portion of the water content, however, is condensed in the piping, and can enter the tool mechanism, and may cause trouble. So, install an air filter and an oiler between the compressor and the tool. Use 3 HP or larger compressor for each sander.

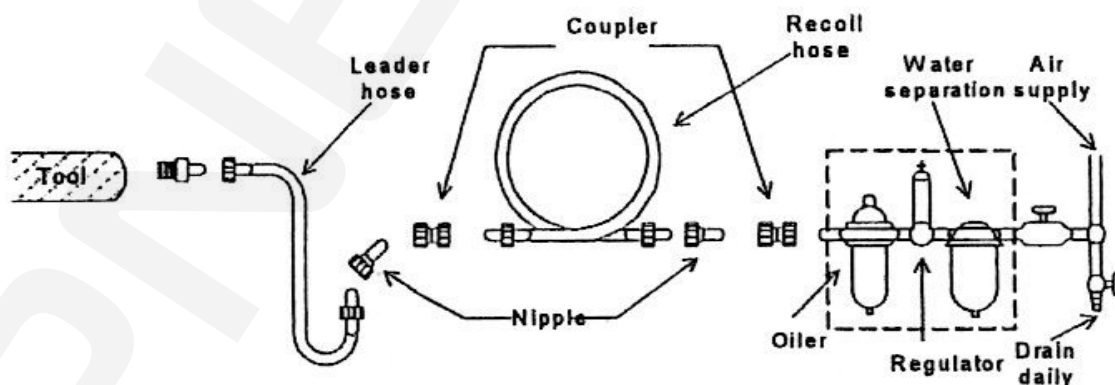

● Air hose

Clean the hose with a blast of compressed air before connecting the hose to air tool. This will prevent both moisture and dust within the hose from entering the tool and causing possible rust or malfunction. To compensate for unusually long hose (over 25 ft), the line pressure should be increased accordingly.

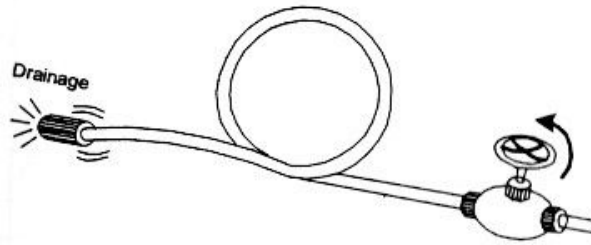

- The approved eye protector, ear-muff, mouth-muffle, and gloves shall be worn when operate this tool.
- The working place shall be ventilative.
- Release the on-off device in the case of energy supply failure.

■ **Operation, Adjusting and Replacing Method**

● On-off device

To operate this tool, just push the lever (straight type) or trigger (Gun grip type) down. The tool continuously rotating as one push the lever trigger down and it might last running for few second.

For the sake of safety, put it on a hanger or on soft flat pad when not in use.

● Change the drill bit

Disconnect the tool before attempting to put a drill bit on this tool. Use attached chuck key to untighten the collet, then insert an appropriate drill bit according to which kind of material that you will drill hole on as deep as it can reach. Then tighten the collet again with the chuck key.

● Rotating direction

If your tool is reversible, you can change the rotating direction by switch the direction lever near the trigger to your desired direction. Forward which is marked with an "F", means clockwise direction and reverse, which is marked "R", indicates the counterclockwise direction. Before start operating this tool, please make sure the rotating direction.

- Use a center punch to locate the center on where you wish to locate the new hole then apply this tool. It will not only be more precise but also prevent from the risk caused by the slip of a rotating drill bit.
- If the drill bit penetrate the workpiece, keep the tool running makes it more easy to remove this tool from workpiece.

■ **Maintenance**

● Lubrication

Before connecting the hose, apply 4 or 5 drops of #60 spindle oil at the air inlet. Use of a thicker oil can lead to reduced performance or malfunction. If a thicker oil is used by accident, wash it away immediately. Also, every 3 or 4 hours of operation, oiling is necessary.

● Storage

Avoid storing the tool in a location subject to high humidity. If the tool is left as it is used, the residual moisture inside the tool can cause rust. Before storing and after operation, oil the tool at the air inlet with spindle oil and run it for short time.

● Disposal

If the tool is too seriously damaged to be used any more, drop it in a resource recycling can. Never drop it into fire.

● Ordering service Parts

For further operational and handling information or of replacement of parts and components, contact the sale agent from whom you purchased the tool or the service division of our company.

** In ordering parts and components, give each part number, name and quantity.*

Warning

- This tool is not insulated for coming into contact with electric power source.
- It is forbidden to use this tool in explosive atmospheres and do not put any combustible material near the workpiece since it emit sparks when grind with metal material.
- The drilled trash might be very sharp. Be careful while deals with this trash.
- Prevent long hair or loose clothing from drawing in while operate this tool.
- Never carry the tool by hose and beware of a whipping compressed air hose.
- The workpiece shall be fixed by proper device.
- Keep your body well balanced as you operate this tool and make sure that no people are within immediate range of tool operation.
- Disconnect tool when not in use and attempt changing the drill bit.
- Do not link the chuck key to this tool in any means. The key shall be placed separately from this tool.

ST-4431(C) 3/8" Air Reversible Drill

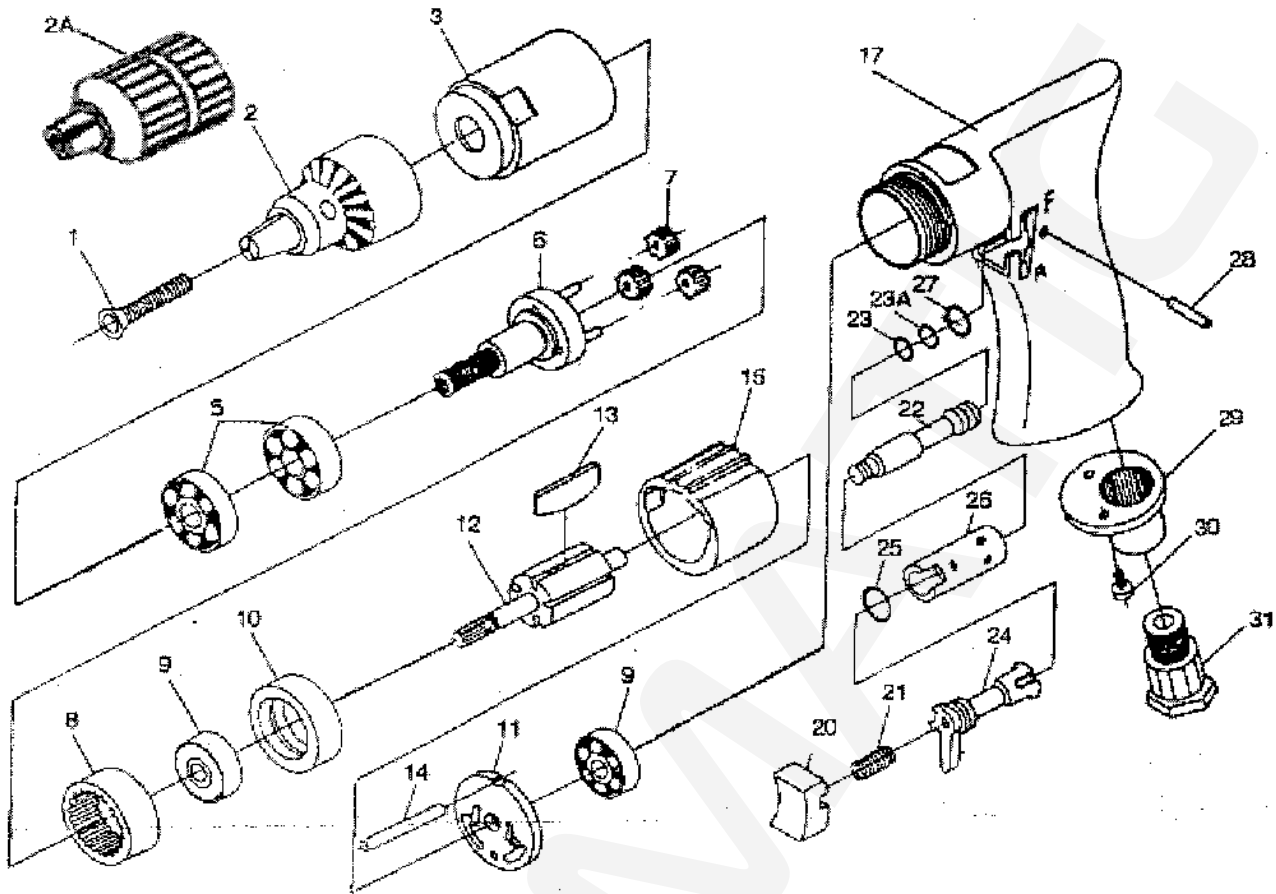

PART LIST

No.	Parts No.	Description	Q'ty	No.	Parts No.	Description	Q'ty
1	4431-01	Screw [M5x20]	1	20	4431-20	Trigger	1
2	4431-02	Drill Chuck [3/8"]	1	20A	4431-20A	Set Screw [M4x6]	1
2A	4431-02C	Keyless Chuck [3/8"]	1	21	4431-21	Valve Spring	1
3	4431-03	Gear Housing	1	22	4431-22	Throttle Valve	1
5	4431-05	Ball Bearing [6201ZZ]	2	23	4431-23	O-Ring [3.5x1.5]	1
6	4431-06	Planet Carrier W/ Needle Roller	1	23A	4431-23A	O-Ring [3.9x2.25x2]	1
7	4431-07	Planet Gear	3	24	4431-24	Reverse Valve	1
8	4431-08	Internal Gear	1	25	4431-25	O-ring [P9]	1
9	4431-09	Ball Bearing	2	26	4431-26	Reverse Valve Bush	1
10	4431-10	Bearing Case	1	27	4431-27	O-Ring [P14]	1
11	4431-11	End Plate	1	28	4431-28	Pin [M2.5x22]	1
12	4431-12	Rotor	1	29	4431-29	Exhaust Deffuser	1
13	4431-13	Rotor Blade	5	30	4431-30	Screw [M3x8]	2
14	4431-14	Motor Pin [2x55]	1	31	4431-31	Air Inlet	1
15	4431-15	Cylinder	1	32	4431-32	Key	1
17	4431-17	Motor Housing	1				