



SUMAKE®

PNEUMATIC TOOLS



1/2" Air Ratchet Wrench ST-5556

SPECIFICATION

Free Speed (rpm)	170
Square Drive (inch)	1/2"
Bolt Capacity (inch)	1/2"
Air Consumption (cfm)	4
Max Torque(ft-lb/Nm)	50 / 68
Air Hose	3/8"
Air Inlet	1/4"
Overall Length (mm)	227
Air Pressure (bar)	6.2
Net Weight (kgs)	1.2

Vibration EN28662-1 EN ISO 28927-2	Noise EN ISO 15744:2008	Remark
No-load: 1,0 m/s ²	Sound pressure level 83 dB Sound power level 95 dB Instantaneous sound pressure 100 dB	Should wear an approved ear - protector and gloves while operating tool.

EC DECLARATION OF CONFORMITY FOR MACHINERY

Manufacturer: SUMAKE INDUSTRIAL CO.,LTD.

Address: 4F,-NO. 351, YANGGUANG ST., NEIHU DISTRICT
TAIPEI CITY 114, TAIWAN

**herewith declares
that:** **1/2" Air Ratchet Wrench
ST-5556**

- is in conformity with the provisions of the Machinery Directive (Directive 2006/42/EC), as amended, and with national implementing legislation:

-and have been tested according to:
EN ISO 12100-1:2003/A1:2009, EN ISO 12100-2:2003/A1:2009, EN 792-6:2000+A1:2008

Taipei, Taiwan Apr / 2 / 2010



Signature

MIKE SU

Full name

Foreword

Sumake is a manufacturer and exporter of air tools since established. We have devote all our effort in improving quality and tools life. As well as the noise and vibration of tools. Bring all of your working efficiency, profits and enjoy using the tool is our principle.

Operator's instruction

■ 1. Main Applications

This asembly tool is the perfect one to which the work of heavy truck, boat, construcion machine, steel belt for excavator etc.

■ 2. Cautions for Use

● 2-1 Air pressure

Maximum performance is displayed at the proper sanding speed, obtainable at a gauge pressure of 6.2 bar. Range-wise, this is an air pressure from 5 to 7 bar (70 to 100 psi)

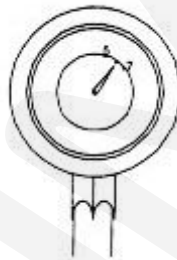

● 2-2 Air line

Use a 3/4" air hose between the compressor and the tool. Compressed air is cooled and its water content separated, as soon as the air leaves the compressor. A portion of the water content, however, is condensed in the piping, and can enter the tool mechanism, and may cause trouble. So, install an air filter and on oiler between the compressor and the tool. Use a 3HP or larger compressor.

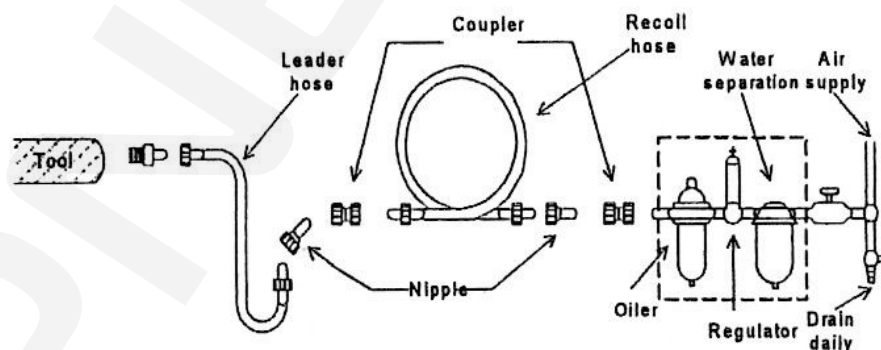

● 2-3 Air hose

Clean the hose with a blast of compressed air before connecting the hose to air tool. This will prevent both moisture and dust within the hose from entering the tool and causing possible rust or malfunction. To compensate for unusually long hose (over 25 ft), the line pressure should be increased accordingly.

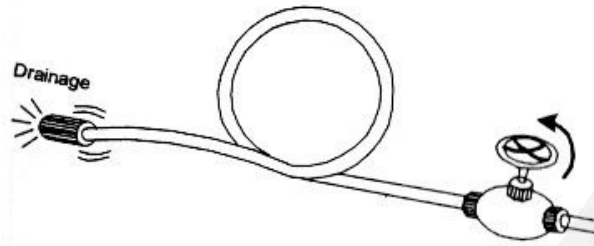

● 2-4 Inserted tools

Use only the socket or adapter which are in good condition for use. The intended socket and adapter for this air tool could be started as "Square Drive" on the specification list.

- 2-5 The approved eye protector, ear-muff, mouth-muffle, and gloves shall be worn when operate this tool.
- 2-6 The working place shall be ventilative.
- 2-7 Release the on-off device in the case of energy supply failure.

■ 3. Operation Method

● 3.1 On-off device

The on-off device is on the inner or outer contour of the grip. It is a "hold-to-run" type. This tool stops rotation within few sec, after releasing the lever. For the sake of safety, place it on a level plate or on hanger after it completely stops.

● 3.2 Torque Adjuster

You can adjust the torque by rotating the knob which indicated by 1 to 6. "1" indicates the smallest torque output and "6" indicates the largest torque output.

● 3.3 Rotating Direction

One shall make sure the direction of rotation before actuate this tool. The "F" indicates forward and the "R" indicates reverse. Forward is defined as clockwise direction seen from the operator's position.

■ 4. Maintenance

● 4-1 Lubrication

Before connecting the hose, apply 4 or 5 drops of #60 spindle oil at the air inlet. Use of a thicker oil can lead to reduced performance or malfunction. If a thicker oil is used by accident, wash it away immediately. Also, every 3 or 4 hours of operation, oiling is necessary.

● 4-2 Storage

Avoid storing the tool in a location subject to high humidity. If the tool is left as it is used, the residual moisture inside the tool can cause rust. Before storing and after operation, oil the tool at the air inlet with spindle oil and run it for short time.

● 4-3 Disposal

If the tool is too seriously damaged to be used any more, drop it in a resource recycling can. Never drop it into fire.

● 4-4 Ordering service Parts

For further operational and handling information or of replacement of parts and components, contact the sale agent from whom you purchased the tool or the service division of our company.

** In ordering parts and components, give each part number, name and quantity.*

Warning

- 1.The power tool shall not be used in potentially explosive atmospheres.
- 2.Disconnect the air hose before changing or adjusting any inserted tools.
- 3.Prevent long hair or loose clothing from drawing in while operate this tool.
- 4.Keep your body in well balanced position and always wear gloves to reduce the risk of crushing caused by torque between handle and workpiece.
- 5.Unexpected direction of rotating could cause a hazardous situation.
- 6.Slip/Trip/Fall is a major reason of serious injury or death. Beware of excess hose left on the walking or work surface.
- 7.Wearing eye/face protector could reduce the danger to person from high speed splinters being emitted from this tool in the case of inserted tool failure or emitted from workpiece
- 8.Wearing mouth-muff could avoid inhaling dust or handling debris from work process that can be harmful to your health.
- 9.Excessive high air pressure and too much free rotation may speed the wear of this tool and might cause danger situation.

ST-5556 1/2" AIR RATCHET WRENCH

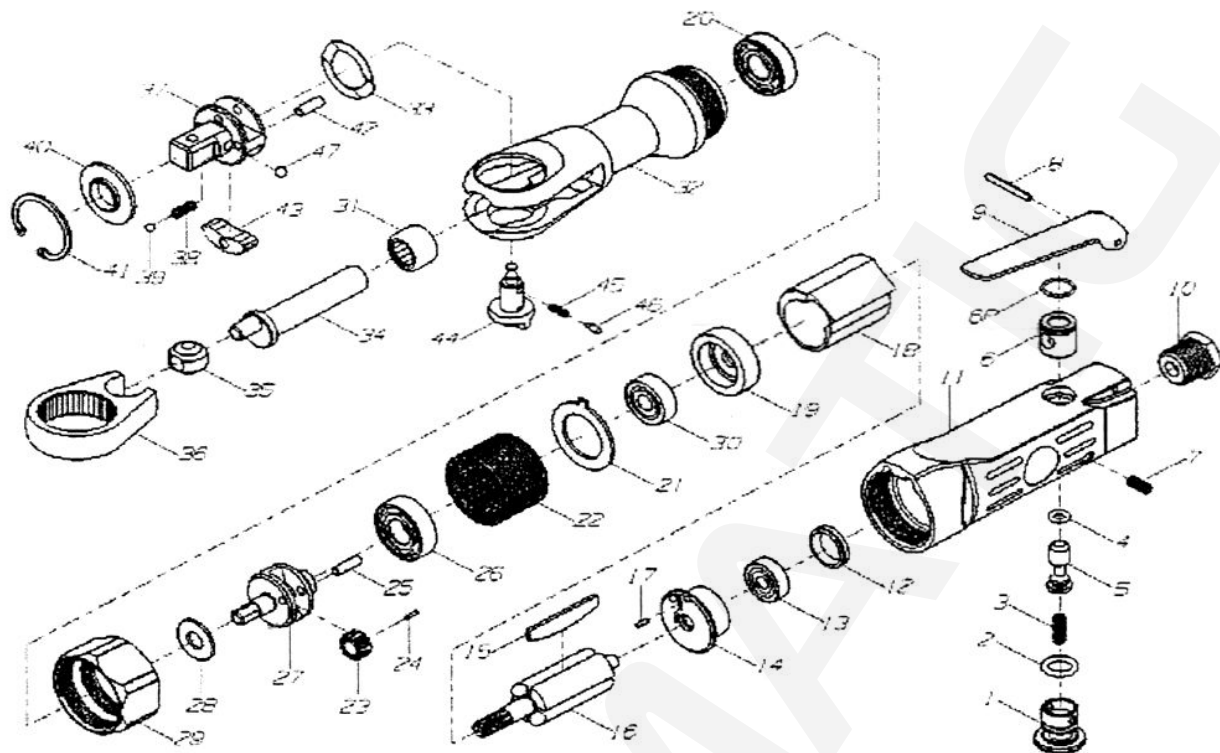

PARTS LIST

No.	Parts No.	Description	Q'ty	No.	Parts No.	Description	Q'ty
1	5556-0	Regulator	1	25	5556-2	Planet Pin	2
2	5556-0	O-Ring	1	26	5556-2	Ball Bearing	1
3	5556-0	Valve Spring	1	27	5556-2	Planet Cage	1
4	5556-0	O-Ring	1	28	5556-2	Washer	1
5	5556-0	Valve Stem	1	29	5556-2	Clamp Nut	1
6	5556-0	Valve Bushing	1	30	5556-3	Ball Bearing	1
6P	5556-0	O-Ring	1	31	5556-3	Needle Bearing	1
7	5556-0	Screw	1	32	5556-3	Ratchet Housing	1
8	5556-0	Lever Pin	1	33	5556-3	Washer	1
9	5556-0	Lever	1	34	5556-3	Crank Shaft	1
10	5556-1	Inlet Bushing	1	35	5556-3	Drive Bushing	1
11	5556-1	Motor Housing	1	36	5556-3	Yoke	1
12	5556-1	Bearing Cap	1	37	5556-3	Ratchet Anvil	1
13	5556-1	Ball Bearing	1	38	5556-3	Spring	2
14	5556-1	Rear End Plate	1	39	5556-3	Steel Ball	2
15	5556-1	Rotor Blade	4	40	5556-4	Thrust Washer	1
16	5556-1	Rotor	1	41	5556-4	Retaining Ring	1
17	5556-1	Pin	1	42	5556-4	Dowel Pin	1
18	5556-1	Cylinder	1	43	5556-4	Pawl	1
19	5556-1	Front End Plate	1	44	5556-4	Reverse Button	1
20	5556-2	Ball Bearing	1	45	5556-4	Spring	1
21	5556-2	Washer	1	46	5556-4	Lock Pin	1
22	5556-2	Internal Gear	1	47	5556-4	Steel Ball	1
23	5556-2	Gear [Incl. 24]	2	48	5556-4	Cover (Opt.)	1
24	5556-2	Needle Roller	22	KIT	5556-KIT	Anvil Kit [Incl. 33,37-43,47]	1